

UPUTSTVO ZA MONTIRANJE  
ASSEMBLING INSTRUCTION  
MONTAGEANLEITUNG  
INSTRUCTIONS D'ASSEMBLAGE  
INSTRUCCIONES DE MONTAJE

ISTRUZIONI PER L'INSTALLAZIONE  
ИНСТРУКЦИЯ ПО МОНТАЖУ  
MONTÁŽNÍ NÁVOD  
ΟΔΗΓΙΕΣ ΣΥΝΑΡΜΟΛΟΓΗΣΗΣ  
INSTRUCȚIUNI DE MONTAJ

ИНСТРУКЦИЯ ЗА МОНТАЖ  
SZERELÉSI UTASÍTÁS  
NAVODILA ZA MONTAŽO  
UPUTE ZA MONTAŽU  
UPUTSTVO ZA MONTIRANJE

УПАТСТВО ЗА МОНТИРАЊЕ  
UDHËZIMET PËR MONTIM  
INSTRUKCJA MONTAŻU  
INSTRUÇÕES DE MONTAGEM  
MONTAGE INSTRUCTIE

# TOMY 2NO1F

**CODE: UP 01051**  
**Version: 02-09112020**

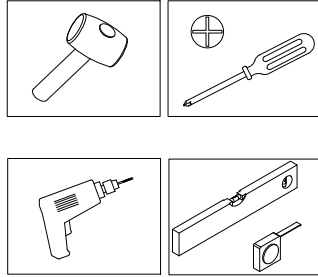
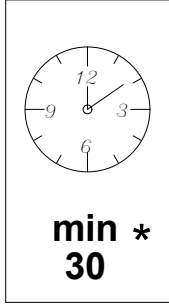
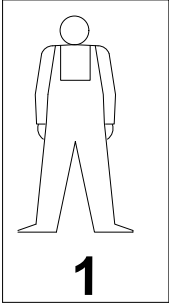

\* **RS ME** Naznačeno vreme montaže važi za stručno obučena lica (profesionalne montažere)/**UK** The specified installation time applies to professionally trained persons (professional installers)/**DE AT CH** Die bezeichnete Zeit der Montage gilt für fachlich geschulte Personen (professionelle Monteure) / **FR CH** Le temps d'installation spécifique s'applique aux personnes formées professionnellement (installateurs professionnels) / **ES** El tiempo de instalación especificado se refiere a personas profesionalmente capacitadas (instaladores profesionales) / **IT CH** tempo di installazione indicato vale per le persone professionalmente preparate (installatori professionali) / **RUS** Приведённое время монтажа действительно для специально обученных лиц (профессиональных монтажников) / **CZ** Uvedená doba montáže se vztahuje na odborně způsobilé osoby (profesionální montér) / **EL** Ο αναφερόμενος χρόνος εγκατάστασης ισχύει για εκπαιδευμένα άτομα (επαγγελματίες εγκαταστάτες) / **RO** Timpul de instalare specificat se aplică persoanelor instruite profesional (instalatori profesioniști) / **BG** Посоченото време за монтаж се отнася за професионално обучени лица (професионални монтажници) / **HU** Az összeszerelés megjelölt ideje a szakképzett személyekre vonatkozik (hivatásos összeszerelők) / **SL** Navedeni čas namestitve (montaže) velja za strokovno usposobljene osebe (strokovne monterje) / **HR** Navedeno vrijeme montaže odnosi se na stručno osposobljene osobe (profesionalne montažere) / **BIH** Naznačeno vrijeme montaže važi za stručno obučena lica (profesionalne montažere) / **MK** Назначеното време за монтажа важи за стручно обучени лица (професионални монтажери) / **AL** Koha e specifikuar e instalimit zbatohet në rast të personave me trajnim profesional (instalues profesionistë) / **PL** Znacznony czas montażu dotyczy przeszkolonych zawodowo osób (profesjonalnych monterów) / **PT** O tempo de montagem indicado aplica-se a pessoas profissionalmente treinadas (instaladores profissionais) / **NL BE** De aangegeven installatietijd is geldig voor professioneel opgeleide personen (professionele installateurs).



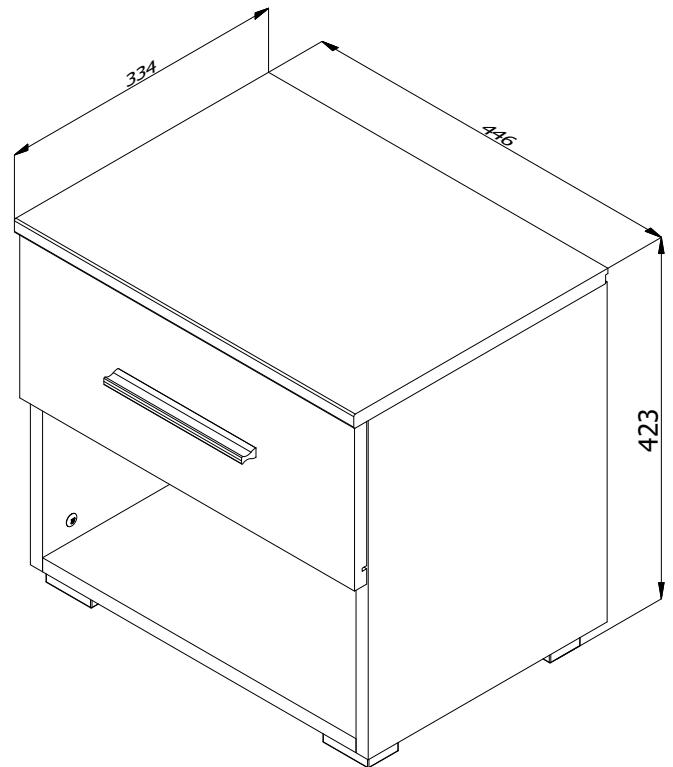
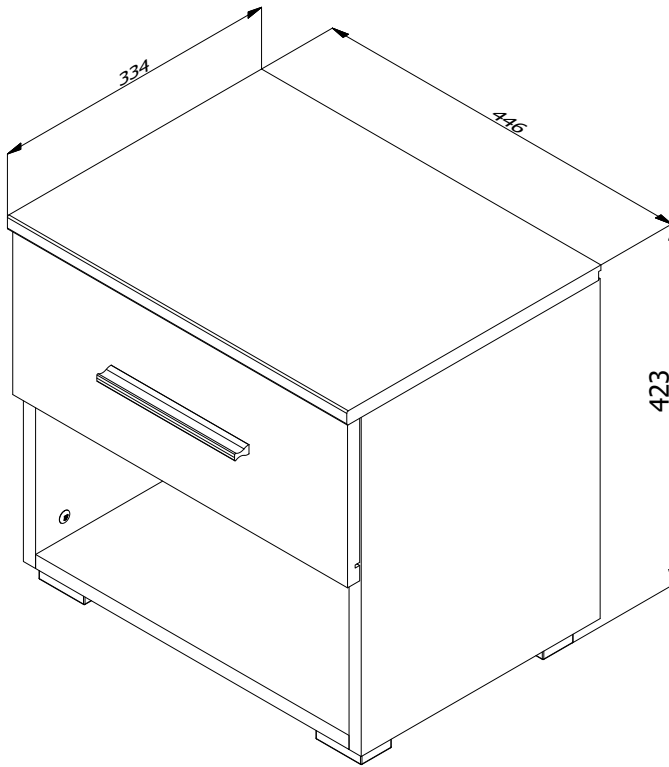





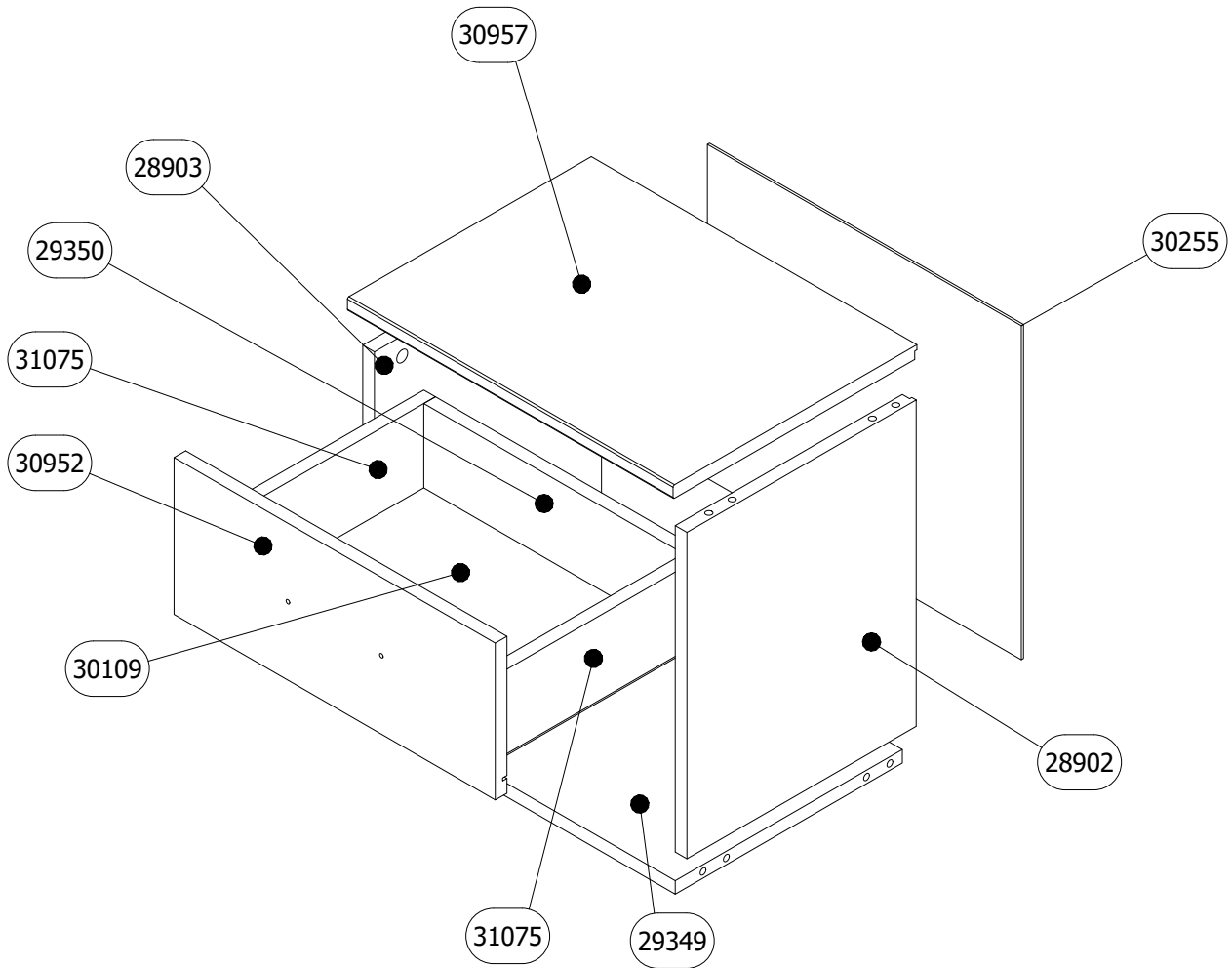



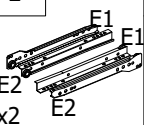

**RS ME** PRE POČETKA MONTIRANJA OBAVEZNO PROČITAJTE UPUTSTVO ZA MONTAŽU / **UK** BEFORE STARTING, REFER TO THE ASSEMBLING ADVICE IN ANNEX / **DE AT CH** VOR DER MONTAGE BITTE BEILIEGENDE ANWEISUNGEN LESEN / **FR CH** AVANT LE DÉBUT DE L'ASSEMBLAGE, S'IL VOUS PLAÎT, LISEZ L'INSTRUCTION D'ASSEMBLAGE / **ES** ANTES DE EMPEZAR EL MONTAJE, LEER CUIDADOSAMENTE LAS INSTRUCCIONES DEL ANEXO / **IT CH** PRIMA DI INIZIARE L'INSTALLAZIONE SI RACCOMANDA DI LEGGERE LE ISTRUZIONI DI INSTALLAZIONE / **RUS** ДО НАЧАЛА МОНТАЖА ОЗНАКОМЬТЕСЬ С ИНСТРУКЦИЕЙ / **CZ** SEZNAMTE SE S NÁVODEM PŘED MONTÁŽÍ NÁBYTKU / **EL** ΠΡΙΝ ΞΕΚΙΝΗΣΕΤΕ ΤΗ ΣΥΝΑΡΜΟΛΟΓΗΣΗ, ΟΠΩΣΔΗΠΟΤΕ ΔΙΑΒΑΣΤΕ ΤΙΣ ΟΔΗΓΙΕΣ ΣΥΝΑΡΜΟΛΟΓΗΣΗΣ / **RO** ÎNAINTE DE ÎNCERPEREA MONTAJULUI ESTE OBLIGATORIE CITIREA INSTRUCȚIUNILOR / **BG** ПРЕДИ МОНТИРАЊЕ НЕ ЗАБРАВЯЙТЕ ДА СЪ ЧЕТЕ ИНСТРУКЦИИ ЗА МОНТАЖ / **HU** SZERELÉS ELŐTT OKYVETLENÜL OLVASSA EL A HASZNÁLATI UTASÍTÁST / **SL** PRED ZAČETKOM MONTAŽE OBEZNO PREBERITE NAVODILA / **HR** PRIJE MONTAŽE UPOZNATI SE SA UPUTSTVOM / **BIH** PRE POČETKA MONTIRANJA OBAVEZNO PROČITAJTE UPUTSTVO ZA MONTAŽU / **MK** ПРЕД ПОЧЕТОК НА МОНТИРАЊЕ ЗАДОЛЖИТЕЛНО ДА СЕ ПРОЧИТА УПАТСТВОТО ЗА МОНТИРАЊЕ / **AL** PARA FILLIMIT TË MONTIMIT LEXONI PATJETËR UDHËZIMIN PËR MONTIM / **PL** PRZED ROZPOCZĘCIEM MONTAŻU PROSZĘ ZAPOZNAĆ SIĘ Z INSTRUKCJĄ / **PT** ANTES DE INICIAR A MONTAGEM, CERTIFIQUE-SE DE LER AS INSTRUÇÕES DE MONTAGEM / **NL BE** LEES DE MONTAGE INSTRUCTIE VOORDAT U MET DE INSTALLATIE BEGINT



28902	387 mm	314 mm	16 mm	2
28903	387 mm	314 mm	16 mm	2
29349	412 mm	311 mm	16 mm	2
29350	356 mm	100 mm	16 mm	2
30109	386 mm	304 mm	3 mm	2
30255	430 mm	396 mm	3 mm	2
30952	440 mm	186 mm	16 mm	2
30957	334 mm	446 mm	16 mm	2
31075	300 mm	100 mm	16 mm	4





Package 1/1	
28902	2
28903	2
29349	2
29350	2
30109	2
30255	2
30952	2
30957	2
31075	4

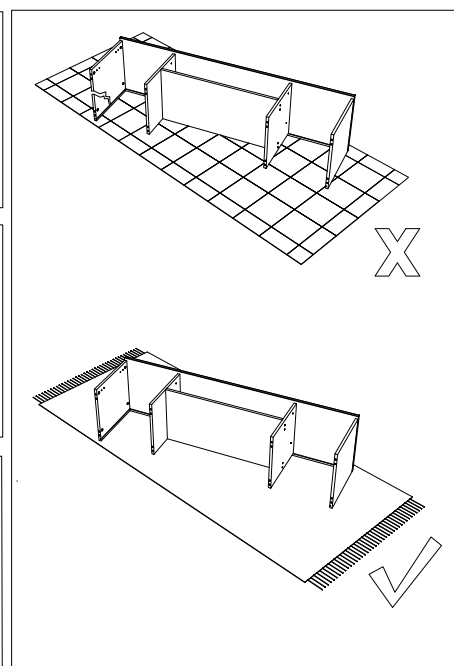
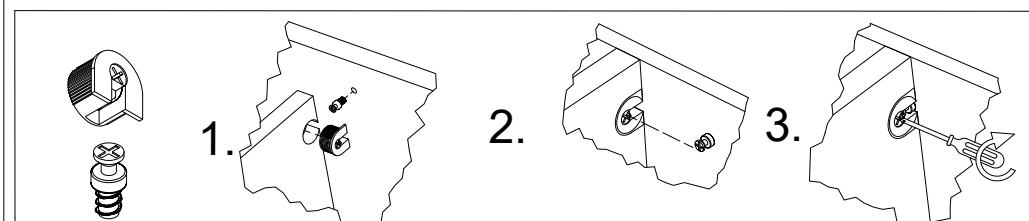
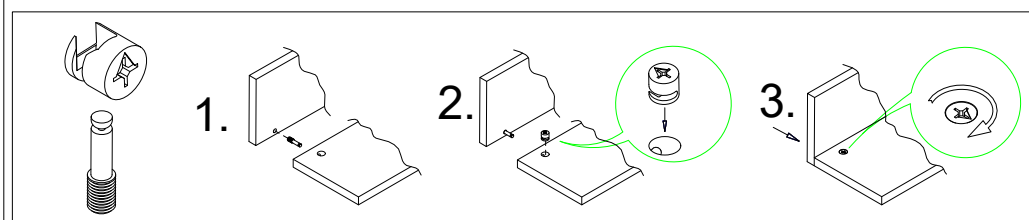
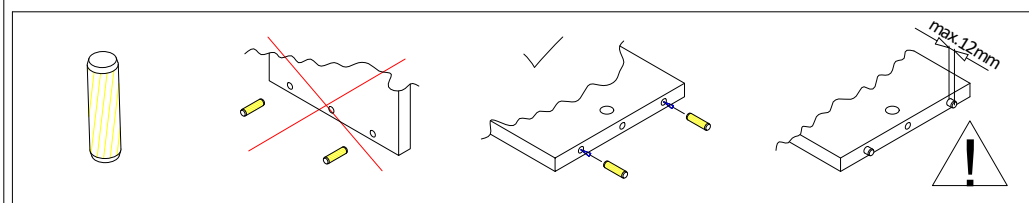

A	B	C	D	E	F	G	H	I	J
									
x20	x24	x8	x20	x2	x8	x8	x16	x6	x8
K	L	M	N	O	P	Q	R	S	T
									
x4	x4	x2	x4	x24					

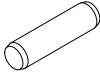

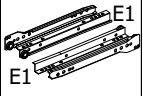

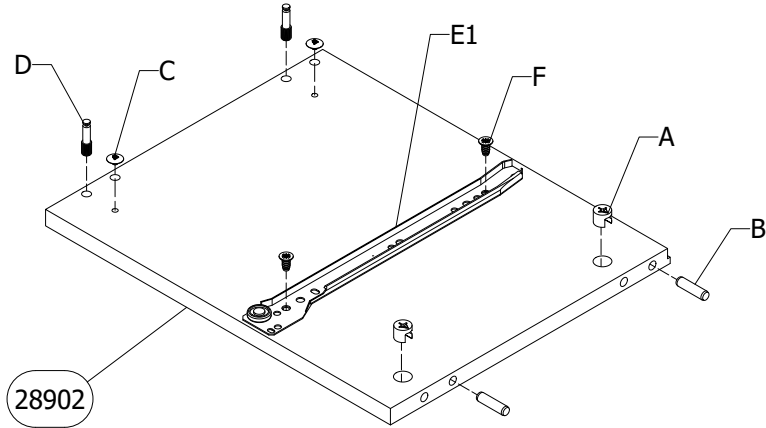

<p><b>RS ME</b></p> <p>1. Montažu obavljati na čistoj i mekoj podlozi (karton, tkanina...)  2. Da bi izbegli oštećenja elemenata pridržavati se datih instrukcija.  3. Prilikom prijave reklamacije koristiti date oznake elemenata.</p>	<p><b>FR CH</b></p> <p>1. Effectuer l'assemblage sur une surface propre et douce (carton, tissu...)  2. Afin d'éviter l'endommagement des éléments, respectez les instructions données.  3. Lors de l'application de réclamation, utiliser les désignations données des éléments.</p>
<p><b>DE AT CH</b></p> <p>1. Die Montage soll auf sauberer, weicher Fläche durchgeführt werden (Karton, Stoff)  2. Um die Beschädigung der Elemente zu vermeiden, befolgen Sie bitte die angegebenen Instruktionen  3. Bei Reklamationsmeldungen benutzen Sie bitte die angegebenen Kennzeichen der Elemente</p>	<p><b>UK</b></p> <p>1. Assembly of the product should be done on a clean and soft surface (cardboard, fabric)  2. To prevent damage of the product, it is necessary to adhere to the assembly instructions  3. While reporting defective products, please quote codes in manual</p>
<p><b>ES</b></p> <p>1. Realizar el montaje sobre una superficie limpia y suave (cartón, paño)  2. Para evitar daños del producto, atenerse a las instrucciones de montaje  3. Para reportar productos defectuosos, refiérase por favor a los códigos del manual</p>	<p><b>IT CH</b></p> <p>1. Eseguire l'installazione su una base morbida (cartone, tessuto).  2. Seguire le istruzioni per evitare di causare danni agli elementi.  3. In caso della presentazione di reclamo si utilizzano relative indicazioni degli elementi.</p>
<p><b>RO</b></p> <p>1. Montarea se efectueaza pe o suprafata moale si curata (carton, material..)  2. Respectati instructiunile pentru a evita deteriorarea pieselor  3. La transmiterea reclamatiiilor a se folosi inscriptiile date ale pieselor</p>	<p><b>CZ SK</b></p> <p>1. Montáž provádět na čistém a měkkém podkladu (lepenka, látka)  2. Dodržujte přiložené instrukce, abyste předešli poškození součástí  3. Při reklamaci používejte přiložené označení element</p>
<p><b>EL</b></p> <p>1. Η συναρμολόγηση του προϊόντος πρέπει να γίνει σε καθαρή και μαλακή επιφάνεια (χαρτόνι, ύφασμα).  2. Για να μην φθαρούν τα στοιχεία, συμμορφωθείτε με τις οδηγίες που παρέχονται.  3. Κατά τη δήλωση ελαττωματικού προϊόντος, αναφέρετε τους κώδικες των στοιχείων όπως αναφέρονται στο εγχειρίδιο.</p>	<p><b>RUS BLR</b></p> <p>1. Монтаж изделия выполнять на чистой и мягкой поверхности (картон, ткань)  2. Для предотвращения порчи изделий необходимо придерживаться правил монтажа  3. В случае предъявления претензии использовать данные обозначения элементов.</p>
<p><b>BG</b></p> <p>1. Монтажът трябва да бъде извършен върху чиста и мека основа /karton, тъкан/  2. За да избегнете оцетяване на елементи, спазвайте дадените инструкции  3. При наличие на рекламация, използвайте дадените кодове на елементи</p>	<p><b>HU</b></p> <p>1. A szerelés tisztaság és puha felületen (karton, anyag) kell végreajtani.  2. Károsodásnak elkerülése érdekében, tartsa be a megadott utasításokat.  3. Reklamáció esetén hivatkozzon a bútor alkatrészein megadott jelekre.</p>
<p><b>SL</b></p> <p>1. Montažo opravimo na čisti in mehki podlogi (karton, tkanina)  2. Da bi se izognili poškodbam elementov, upoštevajte navodila.  3. Pri reklamaciji uporabimo oznake elementov</p>	<p><b>BIH HR</b></p> <p>1. Montažu obavljati na čistoj i mekoj podlozi (karton, tkanina)  2. Da bi izbegli oštećenja elemenata pridržavati se datih instrukcija  3. Prilikom prijave reklamacije koristiti date oznake elemenata</p>
<p><b>MK</b></p> <p>1. Монтажа да се врши на чиста и мека подлога (karton, ткаенина)  2. За да се избегне оштетување на елементите придржувајте се на дадените инструкции  3. За пријава на рекламиции користете ги дадените ознаки на елементите</p>	<p><b>AL</b></p> <p>1. Montimi të bëhet në sipërfaqe të pastër dhe të butë (karton, pëlhurë)  2. Që t'u shmangeni dëmtimit të elementeve, përmbahuni instrukcioneve të dhëna  3. Me rastin e reklamimit përdorni shenjat e dhëna të elementit</p>
<p><b>PL</b></p> <p>1. Montować należy na czystej i miękkiej powierzchni (karton, tkanina)  2. Aby uniknąć uszkodzenia elementów należy postępować ściśle według instrukcji.  3. Przy zgłaszaniu reklamacji należy posługiwać się załączonymi oznaczeniami elementów.</p>	<p><b>HR</b></p> <p>1. Pažljivo pročitajte upute za montažu  2. Pripremite sve dijelove namještaja  3. Prikupite i provjerite okove za montažu  4. Pripremite potreban alat  5. Pripremite prostor za montažu  6. Počnite montirati  7. Sačuvajte ove ove upute  8. Proizvod je namjenjen isključivo za kućnu uporabu</p>
<p><b>PT</b></p> <p>1. A montagem deve ser feita em uma superfície limpa e macia (papelão, tecido...)  2. Para evitar danos nos elementos, siga as instruções fornecidas.  3. Durante a apresentação de reclamação usar os rótulos dos elementos fornecidos.</p>	
<p><b>NL BE</b></p> <p>1. De installatie moet worden uitgevoerd op een schoon en zacht oppervlak (karton, stof...)  2. Volg de gegeven instructies om schade aan de elementen te voorkomen.  3. Gebruik bij het melden van een klacht de gegeven elementlabels.</p>	



<b>1</b>	A x 4 	B x 4 Ø8x30 	C x 4 	D x 4 	E x 1 	F x 4 Ø6.3x13 
----------	---	--	---	---	---	--



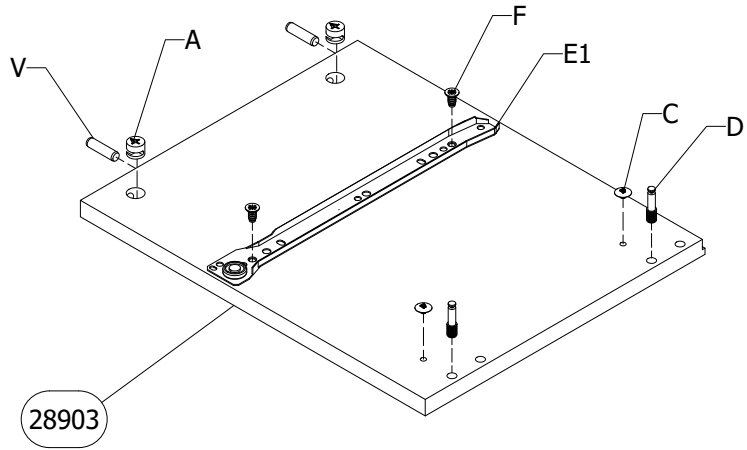

**x2**

<b>2</b>	A x 4 	B x 4 Ø8x30 	E x 1 	F x 4 Ø6.3x13 	D x 4 	C x 4 
----------	--	---	--	---	--	--

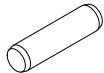

**x2**

<b>3</b>	B x 8 Ø8x30 	A x 8 
----------	---	--

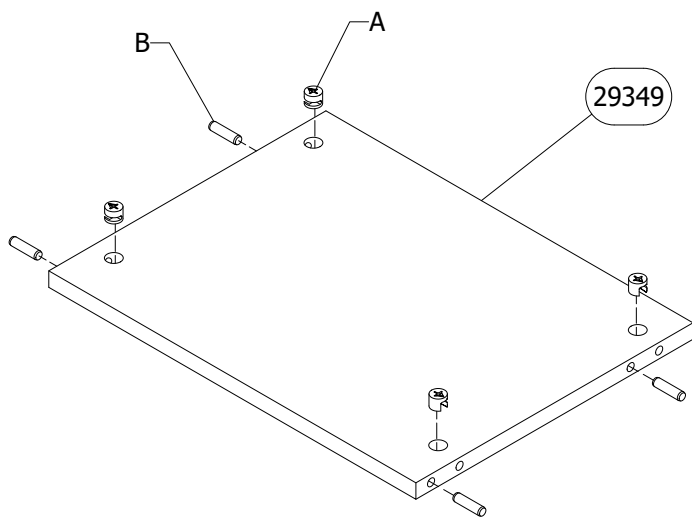

**x2**

4

D x 8

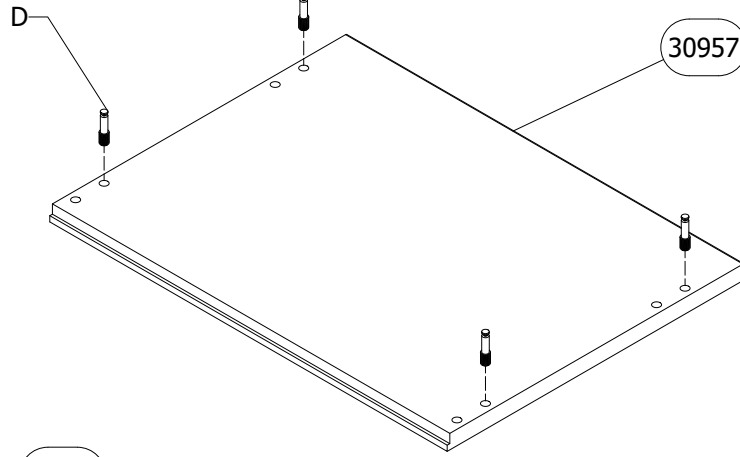

x2

5

28902

28903

29349

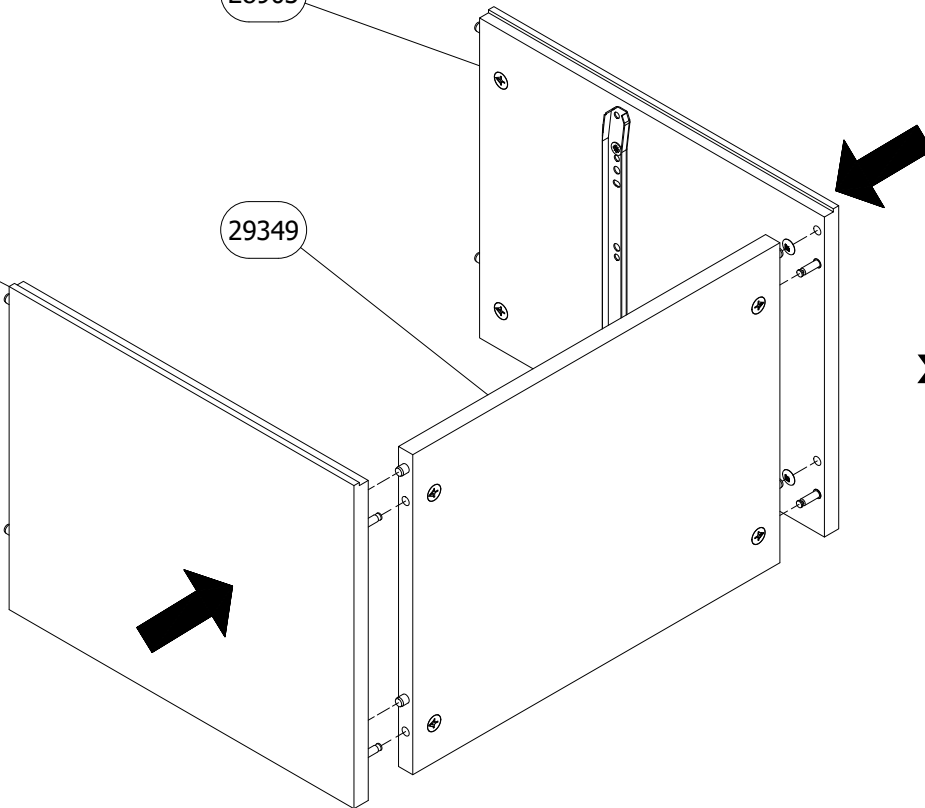

x2

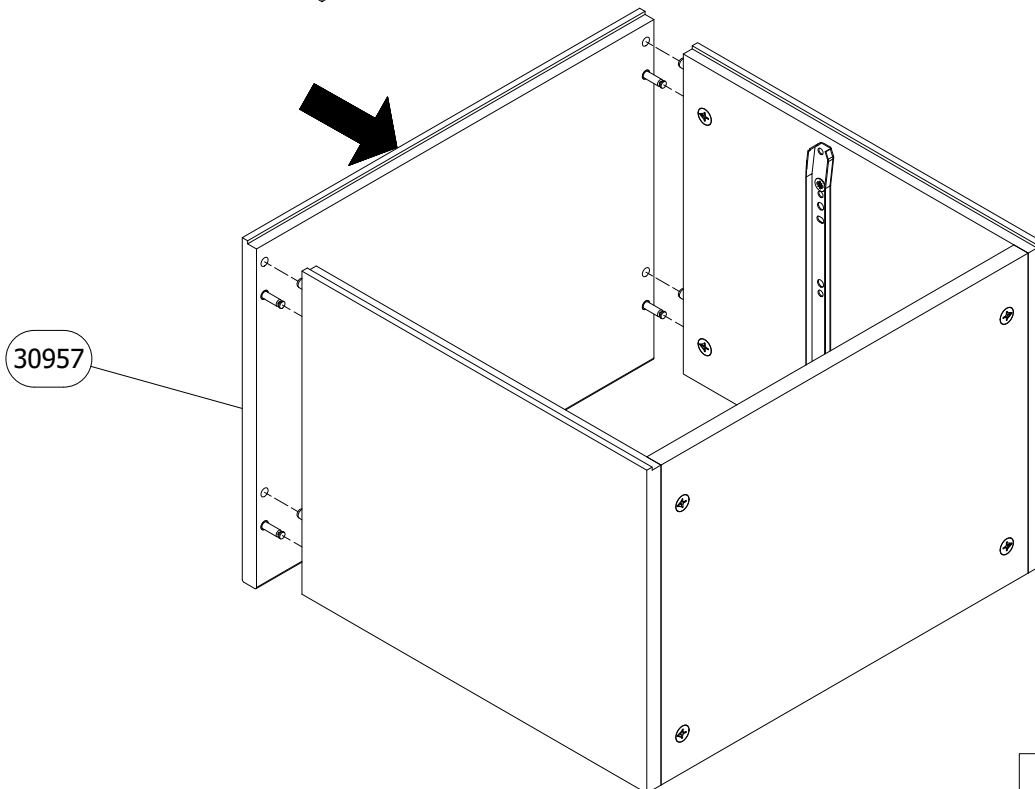

6

30957



x2

7

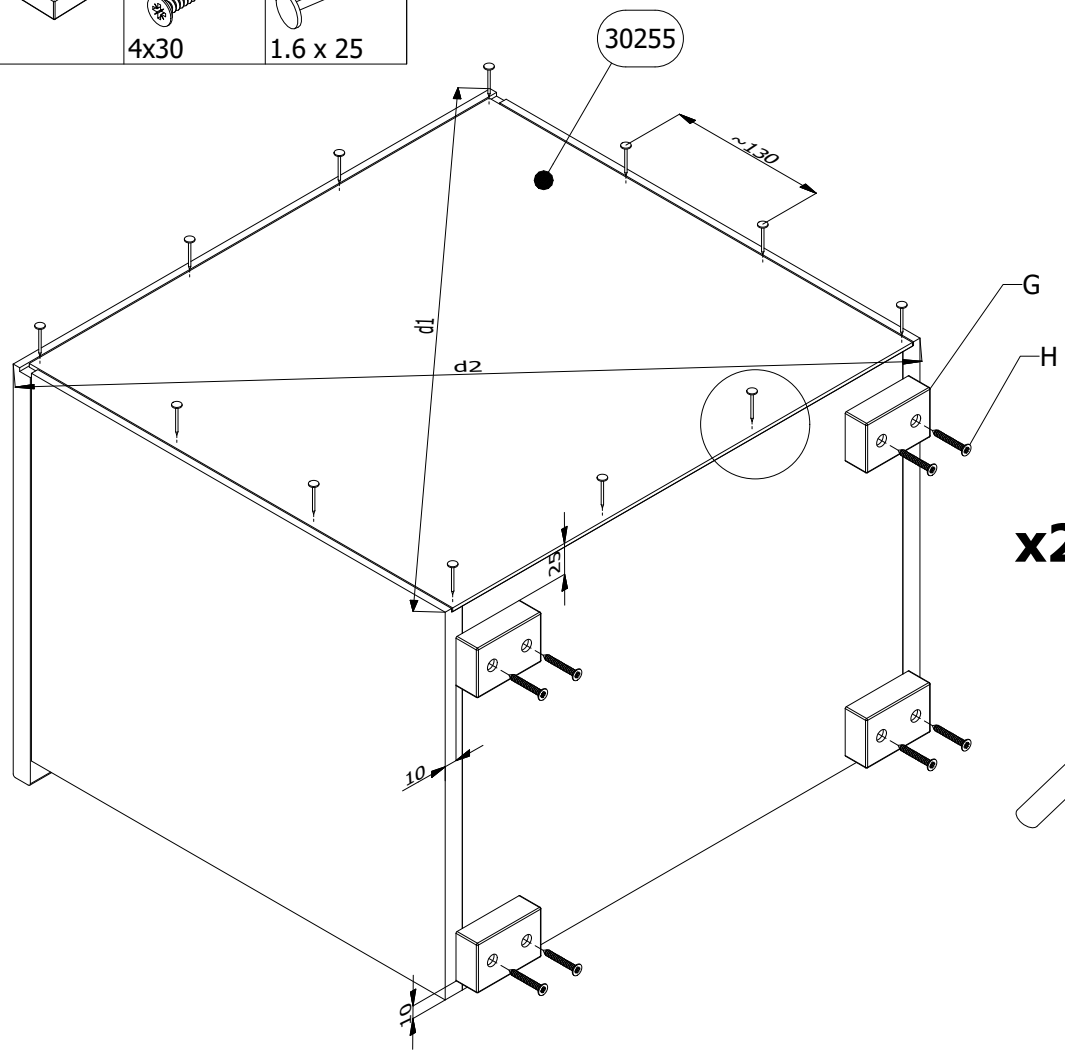

G x 8	H x 16	O x 24
		
	4x30	1.6 x 25

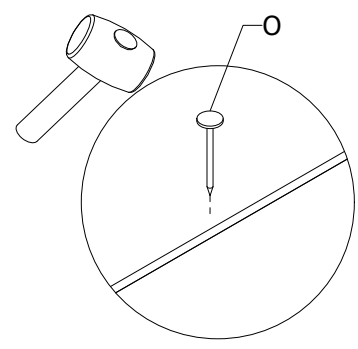
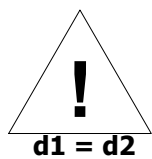

x2



8

A x 4	B x 4
	
	Ø8x30

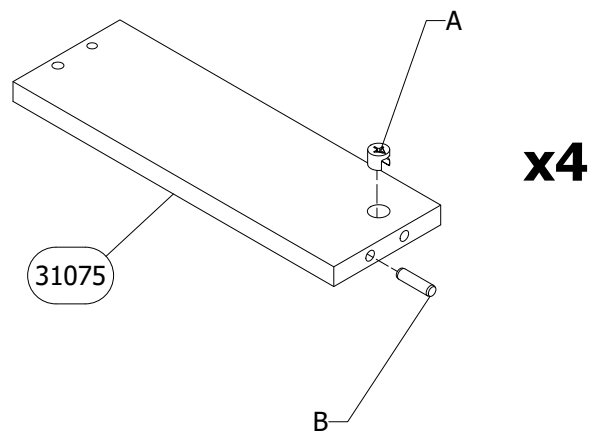

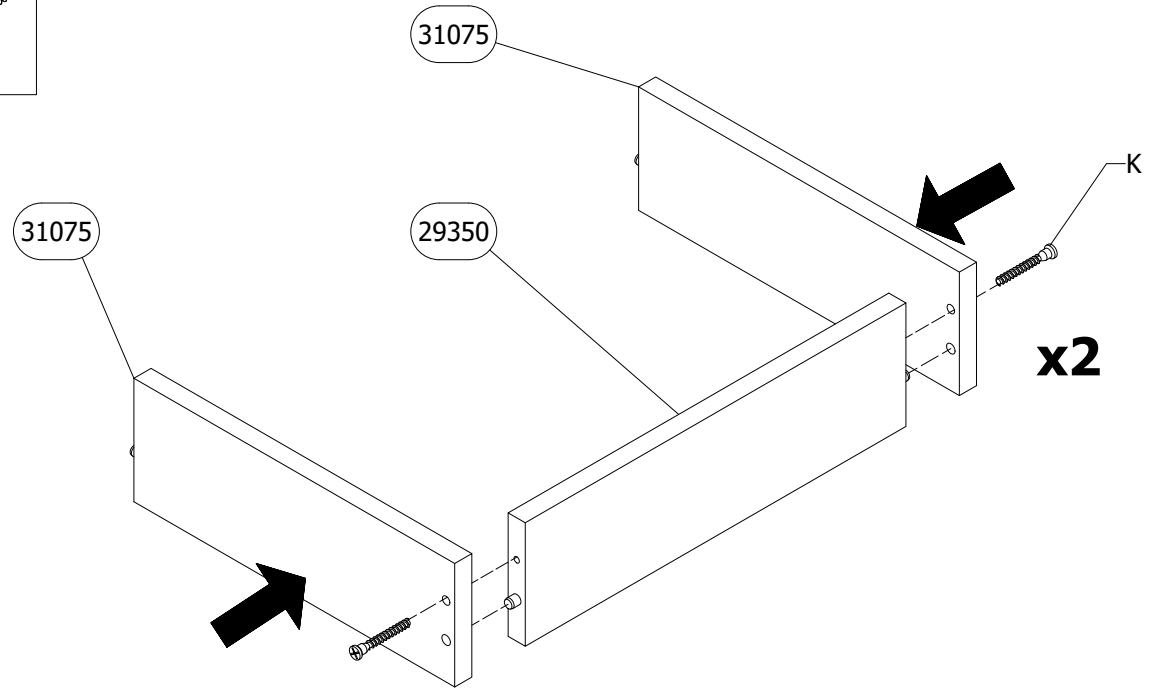
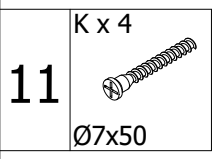
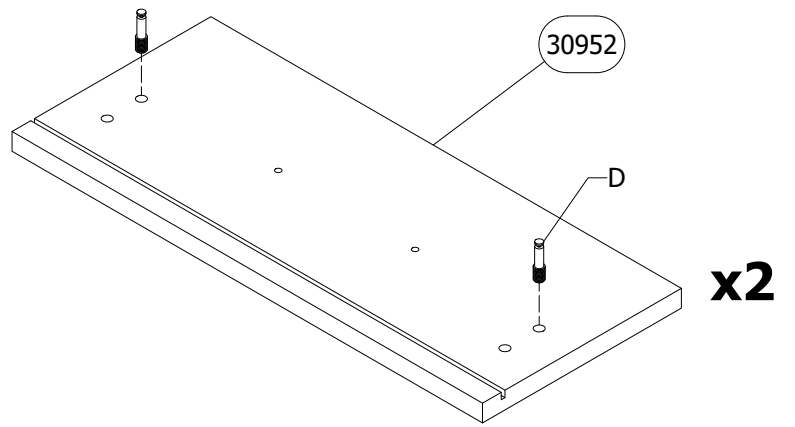
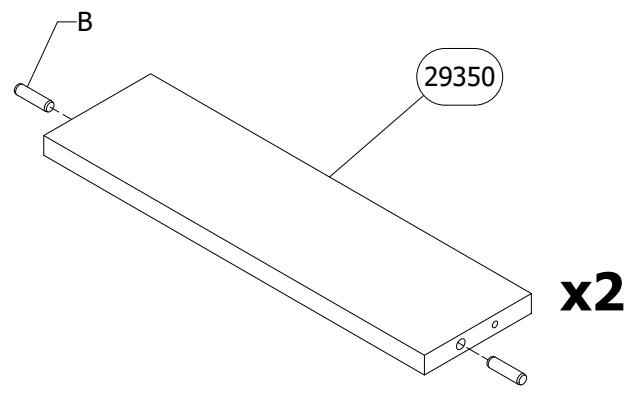
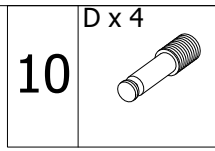
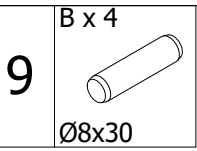

12

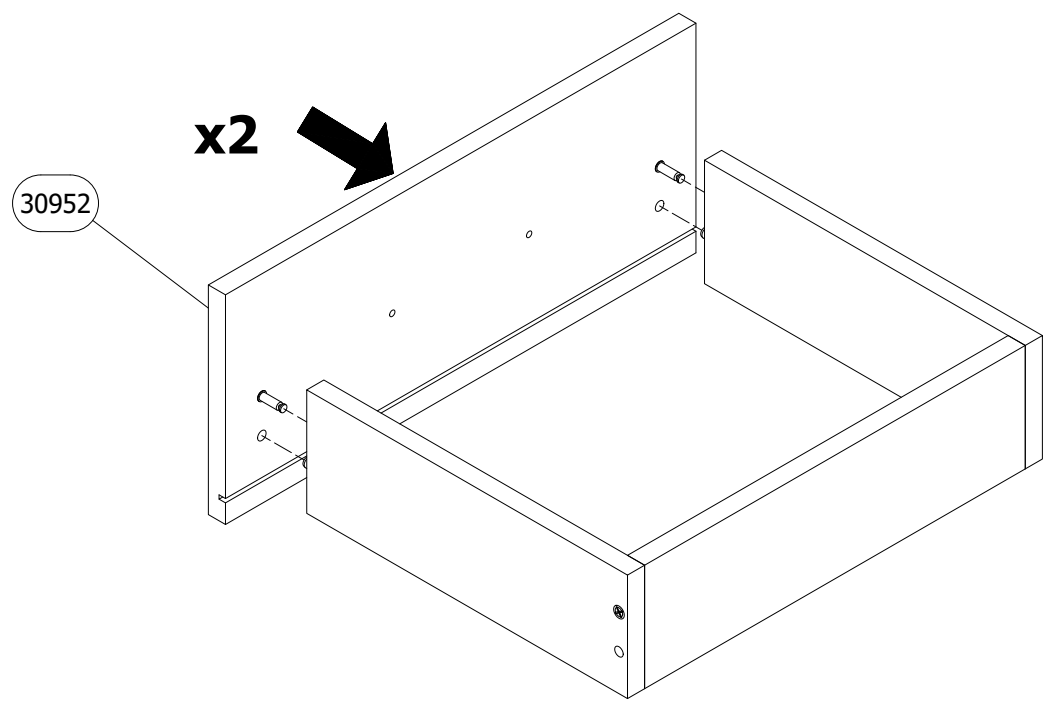

13

E x 2	I x 6	J x 8
	3x25	3.5x16

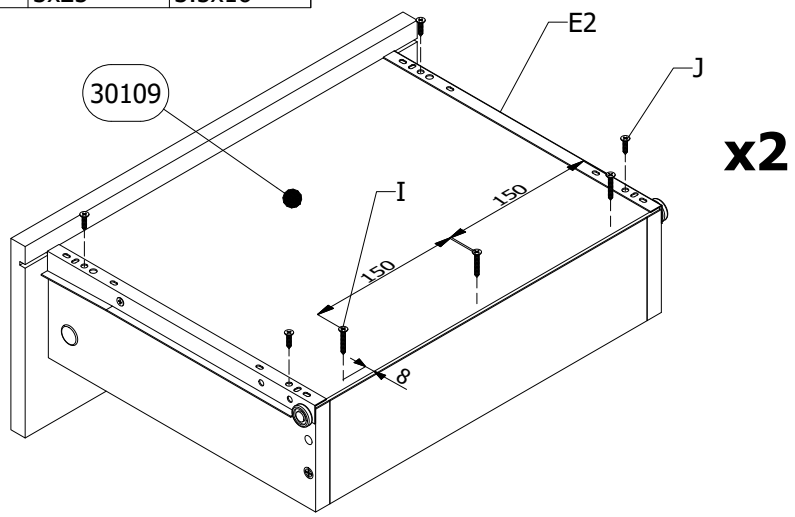

14

L x 4	M x 2	N x 4
		4x30

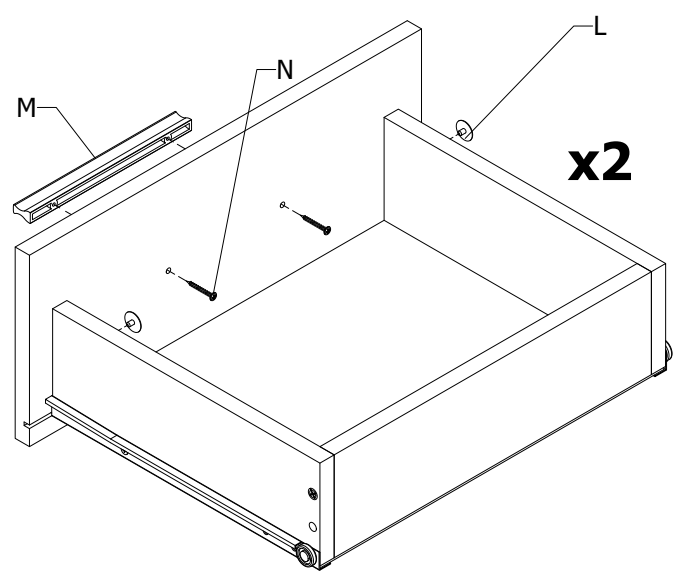

15

x2

